

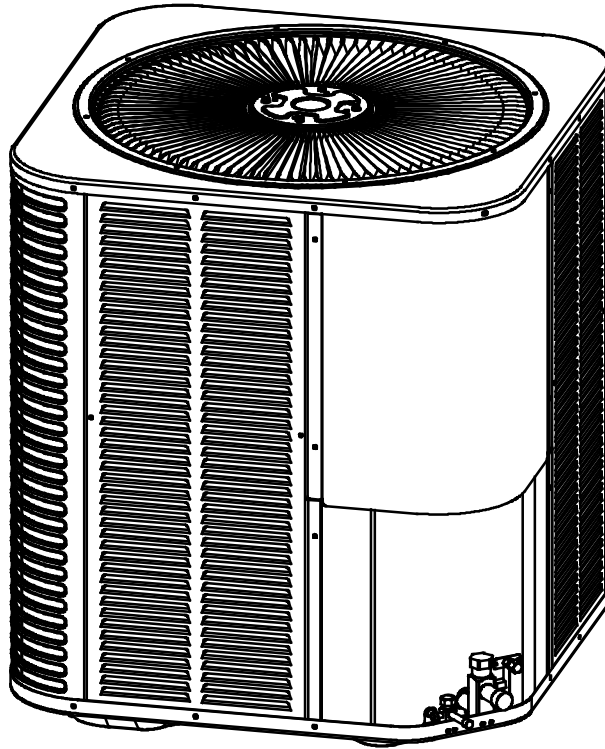

Installation & Operation Instructions For R410A (ADA2 & ADH2) Series 14SEER



RECOGNIZE THIS SYMBOL AS A SAFETY PRECAUTION

ATTENTION INSTALLING PERSONNEL

Prior to installation, thoroughly familiarize yourself with this Installation Manual. Observe all safety warnings.
During installation or repair, caution is to be observed
It is your responsibility to install the product safely and to educate the customer on its safe use

Eair LLC
12201 N.W. 107th Avenue, Medley, FL 33178
www.comfortstarusa.com

TABLE OF CONTENTS

1.0 SAFETY	3
1.1 INSPECTION.....	4
1.2 LIMITATIONS.....	4
2.0 GENERAL	4
3.0 UNIT INSTALLATION	6
3.1 LOCATION.....	6
3.2 GROUND INSTALLATION.....	6
3.3 ROOF INSTALLATION.....	6
3.4 UNIT PLACEMENT.....	6
3.5 PRECAUTIONS DURING LINE INSTALLATION.....	7
3.6 PRECAUTIONS DURING BRAZING OF LINES.....	8
3.7 PRECAUTIONS DURING BRAZING SERVICE VALVE.....	9
3.8 UNIT MOUNTING.....	10
3.9 FACTORY-PREFERRED TIE-DOWN METHOD.....	11
3.10 REMOVING THE TOP PANEL AND MOTOR.....	12
4.0 ELECTRICAL CONNECTIONS	13
4.1 GENERAL INFORMATION & GROUNDING	13
4.2 FIELD CONNECTIONS POWER WIRING	13
5.0 EVACUATION	14
6.0 INTERCONNECTING TUBING	14
6.1 VAPOR AND LIQUID LINES	14
6.2 MAXIMUM LENGTH OF LINES	14
6.3 VERTICAL SEPARATION	14
7.0 SYSTEM OPERATION	14
7.1 COMPRESSOR CRANKCASE HEATER (CCH).....	14
7.2 PROTECTION FUNCTION INTRODUCTION.....	16
7.3 DEFROST MODE INTRODUCTION.....	16
8.0 CHECKING REFRIGERANT CHARGE	16
8.1 CHARGING BY LIQUID PRESSURE.....	17
8.2 CHARGING BY WEIGHT	17
8.3 FINAL LEAK TESTING	17
9.0 INSTRUCTING THE OWNER	20
10.0 WIRING DIAGRAM	20

This document is customer property and is to remain with this unit. These instructions do not cover all the different variations of systems nor does it provide for every possible contingency to be met in connection with installation.

All phases of this installation must comply with NATIONAL STATE AND LOCAL CODES. If additional information is required please contact your local distributor.

1.0 SAFETY



This is a safety alert symbol. When you see this symbol on labels or in manuals, be alert to the potential for personal injury.



This is an attention alert symbol. When you see this symbol on labels or in manuals, be alert to the potential for personal injury.

Understand and pay particular attention to the signal words DANGER, WARNING, or CAUTION.

DANGER indicates an imminently hazardous situation, which, if not avoided, will result in death or serious injury.

WARNING indicates a potentially hazardous situation, which, if not avoided, could result in death or serious injury.

CAUTION indicates a potentially hazardous situation, which, if not avoided may result in minor or moderate injury. It is also used to alert against unsafe practices and hazards involving only property damage.



WARNING

Improper installation may create a condition where the operation of the product could cause personal injury or property damage. Improper installation, adjustment, alteration, service or maintenance can cause injury or property damage. Refer to this manual for assistance or for additional information, consult a qualified contractor, installer or service agency.



CAUTION

This product must be installed in strict compliance with the installation instructions and any applicable local, state, and national codes including, but not limited to building, electrical, and mechanical codes.



WARNING

FIRE OR ELECTRICAL HAZARD

Failure to follow the safety warnings exactly could result in serious injury, death or property damage.

A fire or electrical hazard may result causing property damage, personal injury or loss of life.

1.1 INSPECTION

As soon as a unit is received, it should be inspected for possible damage during transit. If damage is evident, the extent of the damage should be noted on the carrier's delivery receipt. A separate request for inspection by the carrier's agent should be made in writing. See Local distributor for more information.

Requirements For Installing/Serviceing R410A Equipment

- Gauge sets, hoses, refrigerant containers, and recovery system must be designed to handle the POE or PVE type oils.
- Manifold sets should be 800 PSIG high side and 250 PSIG low side with 550 PSIG low side restart.
- All hoses must have a 700 PSIG service pressure rating.
- Leak detectors should be designed to detect refrigerant.
- Recovery equipment (including refrigerant recovery containers) must be specifically designed to handle R410A.
- **Do not use an R-22 TXV.**
- It will be more convenient to open the Service valve after removing the Underside Clpboard. see the Fig.1

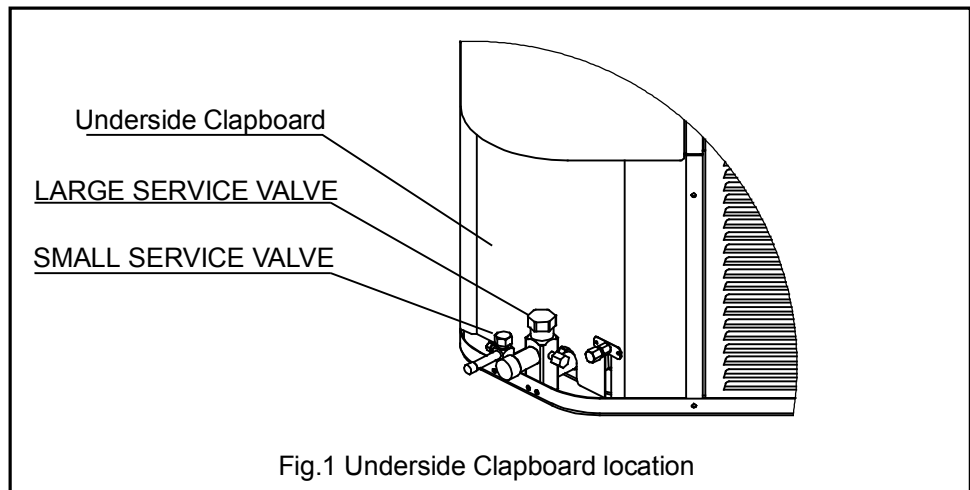

1.2 LIMITATIONS

The unit should be installed in accordance with all National, State and Local Safety Codes and the limitations listed below:

- 1.Limitations for the indoor unit, coil and appropriate accessories must also be observed.
- 2.The outdoor unit must not be installed with any duct work in the air stream. The outdoor fan is the propeller type and is not designed to operate against any additional external static pressure.
- 3.The maximum and minimum conditions for operation must be observed to assure a system that will give maximum performance with minimum service.
- 4.This unit is not designed to operate with a low ambient kit. Do not modify the control system to operate with any kind of low ambient kit.
- 5.The maximum allowable line length for this product is 150 feet (Just for Scroll compressor) .

2.0 GENERAL

The outdoor units are designed to be connected to a matching indoor coil with sweat connect lines. Sweat connect units are factory charged with refrigerant for a matching indoor coil plus 25 feet of field supplied lines.

Matching indoor coils are available with a thermostatic expansion valve or an orifice for the most common usage. The orifice size and/or refrigerant charge may need to be changed for some indoor-outdoor unit combinations, elevation differences or total line lengths.

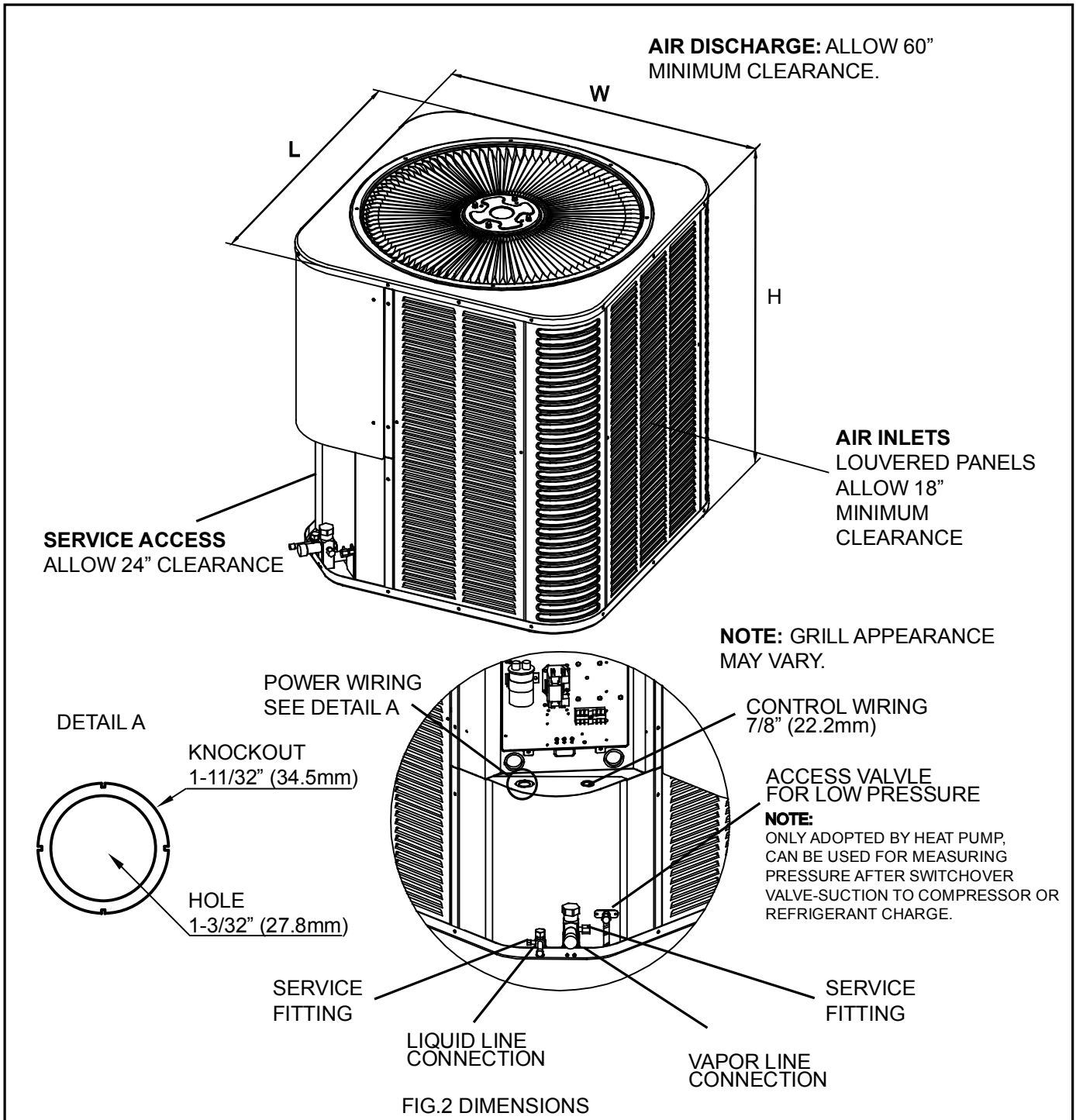

DIMENSIONAL DATA

Unit Model (Btu/h)	Dimensions (Inches)			Refrigerant Connection Service Valve Size	
	"H" in [mm]	"W" in [mm]	"L" in [mm]	Liquid in	Vapor in
18(cooling unit)	24-15/16[633]	21-7/8[554]	21-7/8[554]	3/8	3/4
18(heat pump unit)	24-15/16[633]	23-5/8[600]	23-5/8[600]	3/8	3/4
24	24-15/16[633]	23-5/8[600]	23-5/8[600]	3/8	3/4
30	24-15/16[633]	28[710]	28[710]	3/8	3/4
36	24-15/16[633]	29-1/8[740]	29-1/8[740]	3/8	3/4
42	29-7/8[759]	28[710]	28[710]	3/8	3/4
48	33-3/16[843]	28[710]	28[710]	3/8	7/8
60	33-3/16[843]	29-1/8[740]	29-1/8[740]	3/8	7/8

3.0 UNIT INSTALLATION

3.1 LOCATION

Before starting the installation, select and check the suitability of the location for both the indoor and outdoor unit. Observe all limitations and clearance requirements. The outdoor unit must have sufficient clearance for air entrance to the condenser coil, for air discharge and for service access. See Fig.2



NOTE

For multiple unit installations, units must be spaced a minimum of 18 inches apart. (Coil face to coil face.)

If the unit is to be installed on a hot sun exposed roof or a black-topped ground area, the unit should be raised sufficiently above the roof or ground to avoid taking the accumulated layer of hot air into the outdoor unit.

Provide an adequate structural support.

3.2 GROUND INSTALLATION

The unit may be installed at ground level on a solid base that will not shift or settle, causing strain on the refrigerant lines and possible leaks. Maintain the clearances shown in Fig.2 and install the unit in a level position.

Normal operating sound levels may be objectionable if the unit is placed directly under windows of certain rooms (bedrooms, study, etc.).

Top of unit discharge area must be unrestricted for at least 60 inches above the unit.



WARNING

The outdoor unit should not be installed in an area where mud or ice could cause personal injury.

Elevate the unit sufficiently to prevent any blockage of the air entrances by snow in areas where there will be snow accumulation. Check the local weather bureau for the expected snow accumulation in your area. Isolate the unit from rain gutters to avoid any possible wash out of the foundation.

3.3 ROOF INSTALLATION

When installing units on a roof, the structure must be capable of supporting the total weight of the unit, including a padded frame unit, rails, etc., which should be used to minimize the transmission of sound or vibration into the conditioned space.

3.4 UNIT PLACEMENT

1. Provide a base in the pre-determined location.
2. Remove the shipping carton and inspect for possible damage.
3. Compressor tie-down bolts should remain tightened.
4. Position the unit on the base provided.



CAUTION

This system uses R410A refrigerant which operates at higher pressure than R-22. No other refrigerant may be used in this system. Gauge sets, hoses, refrigerant containers, and recovery system must be designed to handle R410A. If you are unsure, consult the equipment manufacturer.

The outdoor unit must be connected to the indoor coil using field supplied refrigerant grade copper tubing that is internally clean and dry. Units should be installed only with the tubing sizes for approved system combinations. The charge given is applicable for total tubing lengths up to 25 feet.



NOTE

Using a larger than specified line size could result in oil return problems. Using too small a line will result in loss of capacity and other problems caused by insufficient refrigerant flow. Slope horizontal vapor lines at least 1" every 20 feet toward the outdoor unit to facilitate proper oil return.

3.5 PRECAUTIONS DURING LINE INSTALLATION

1. Install the lines with as few bends as possible. Care must be taken not to damage the couplings or kink the tubing. Use clean hard drawn Copper tubing where no appreciable amount of bending around obstruction is necessary, if soft copper must be used, care must be taken to avoid sharp bends which may cause a restriction.
2. The lines should be installed so that they will not obstruct service access to the coil, air handling system or filter.
3. Care must also be taken to isolate the refrigerant lines to minimize noise transmission from the equipment to the structure.
4. The vapor line and liquid line must be insulated with a minimum of 1/2" foam rubber insulation (Armaflex or equivalent). Tape and suspend the refrigerant lines as shown. DO NOT allow tube metal-to-metal contact. See Fig. 3.
5. Use PVC piping as a conduit for all underground installations as shown in Fig. 4. Buried lines should be kept as short as possible to minimize the build up of liquid refrigerant in the vapor line during long periods of shutdown.
6. Pack fiberglass insulation and a sealing material such as perma gum around refrigerant lines where they penetrate a wall to reduce vibration and to retain some flexibility.

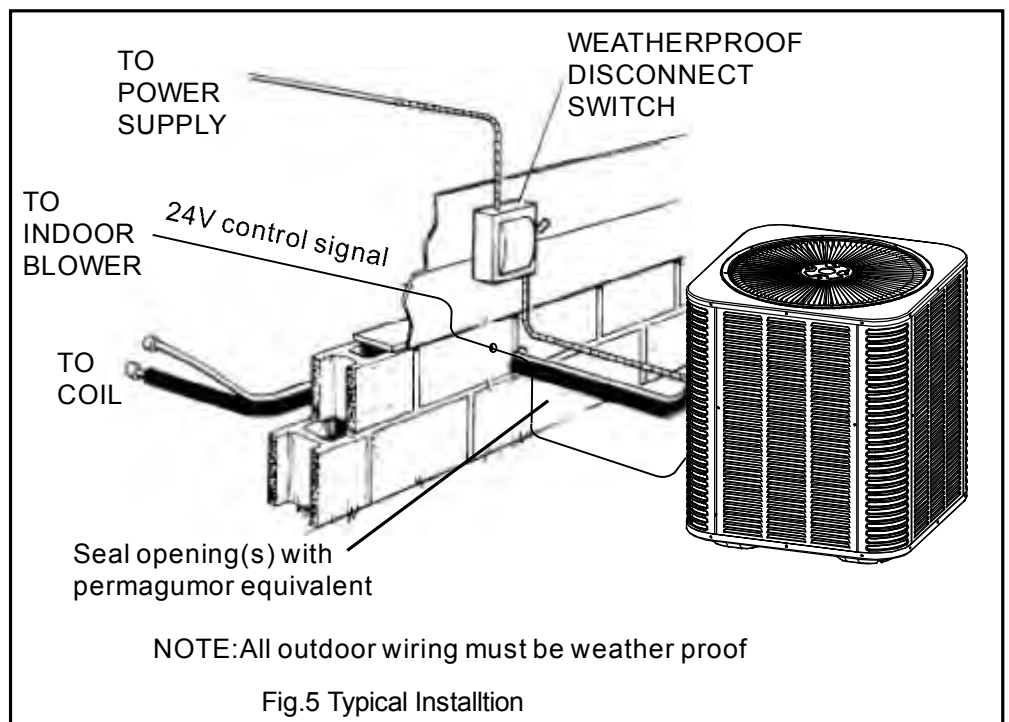
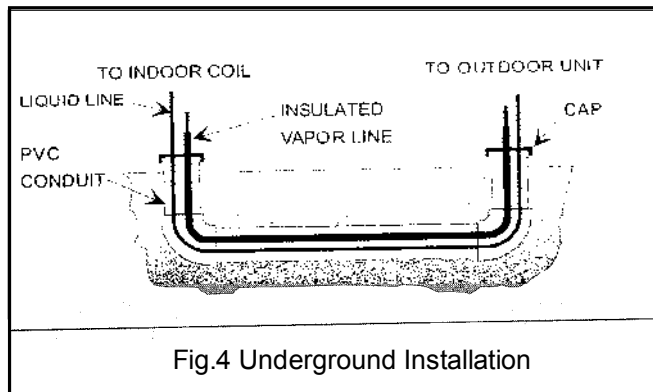
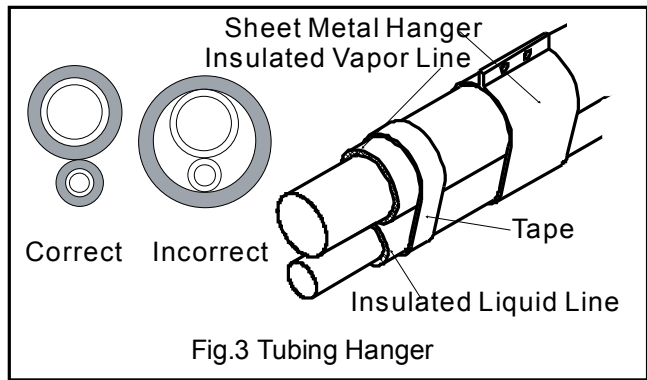

3.6 PRECAUTIONS DURING BRAZING OF LINES

All outdoor unit and evaporator coil connections are copper-to-copper and should be brazed with a phosphorous-copper alloy material such as Silfos-5 or equivalent. DO NOT use soft solder. The outdoor units have reusable service valves on both the liquid and vapor connections. The total system refrigerant charge is retained within the outdoor unit during shipping and installation. The reusable service valves are provided to evacuate and charge per this instruction.

Serious service problems can be avoided by taking adequate precautions to assure an internally clean and dry system.



CAUTION

Dry nitrogen should always be supplied through the tubing while it is being brazed, because the temperature required is high enough to cause oxidation of the copper unless an inert atmosphere is provided. The flow of dry nitrogen should continue until the joint has cooled. Always use a pressure regulator and safety valve to insure that only low pressure dry nitrogen is introduced into the tubing. Only a small flow is necessary to displace air and prevent oxidation.

3.7 PRECAUTIONS DURING BRAZING SERVICE VALVE

Precautions should be taken to prevent heat damage to service valve by wrapping a wet rag around it as shown in Fig. 6. Also, protect all painted surfaces, insulation, during brazing. After brazing cool joint with wet rag.

Valve can be opened by removing the plunger cap and fully inserting a hex wrench into the stem and backing out counter-clockwise until valve stem just touches the chamfered retaining wall.

Connect the refrigerant lines using the following procedure:

1. Remove the cap and Schrader core from both the liquid and vapor service valve service ports at the outdoor unit. Connect low pressure nitrogen to the liquid line service port.

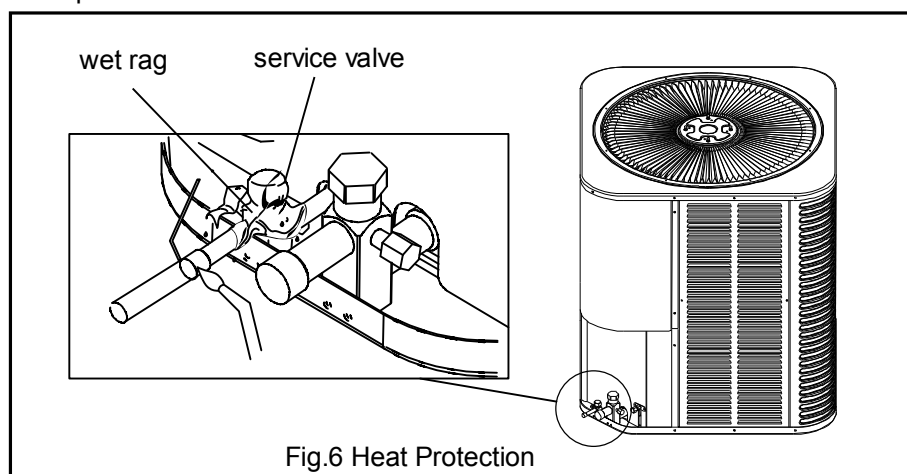



Fig.6 Heat Protection

2. Braze the liquid line to the liquid valve at the outdoor unit. Be sure to wrap the valve body with a wet rag. Allow the nitrogen to continue flowing. Refer to the Tabular Data Sheet for proper liquid line sizing.
3. Carefully remove the rubber plugs from the evaporator liquid and vapor connections at the indoor coil.
4. Braze the liquid line to the evaporator liquid connection. Nitrogen should be flowing through the evaporator coil.
5. Slide the plastic cap away from the vapor connection at the indoor coil. Braze the vapor line to the evaporator vapor connection. Refer to the Table 1 for proper vapor line sizing.
6. Protect the vapor valve with a wet rag and braze the vapor line connection to the outdoor unit. The nitrogen flow should be exiting the system from the vapor service port connection. After this connection has cooled, remove the nitrogen source from the liquid fitting service port.
7. Replace the Schrader core in the liquid and vapor valves.
8. Leak test all refrigerant piping connections including the service port flare caps to be sure they are leak tight. **DO NOT OVER TIGHTEN (between 40 and 60 inch -lbs. maximum).**
9. Evacuate the vapor line, evaporator and the liquid line, to 500 microns or less.

Table 1: Refrigerant Connections and Recommended Liquid and Vapor Tube Diameters (In.)

UNIT	LIQUID	VAPOR	LIQUID (LONG-LINE)
SIZE	Tube Diameter	Tube Diameter	Tube Diameter
18	3/8	3/4	3/8
24	3/8	3/4	3/8
30	3/8	3/4	3/8
36	3/8	3/4	3/8
42	3/8	3/4	3/8
48	3/8	7/8	3/8
60	3/8	7/8	3/8

- Replace cap on service ports. Do not remove the flare caps from the service ports except when necessary for servicing the system.

	CAUTION
Do not connect manifold gauges unless trouble is suspected. Approximately 3/4 ounce of refrigerant will be lost each time a standard manifold gauge is connected.	

- Release the refrigerant charge into the system. Open both the liquid and vapor valves by removing the plunger cap and with an hex wrench back out counter-clockwise until valve stem just touches the chamfered retaining wall.
- Replace plunger cap finger tight, then tighten an additional 1/12 turn (1/2 hex flat). Cap must be replaced to prevent leaks.

	WARNING
Never attempt to repair any brazed connections while the system is under pressure. Personal injury could result.	

See "System Charge" section for checking and recording system charge.

3.8 UNIT MOUNTING

If elevating the heat pump, either on a flat roof or on a slab, observe the following guidelines.

- The base pan provided elevates the heat pump 2" above the base pad.
- If elevating a unit on a flat roof, use 4" x 4" (or equivalent) stringers positioned to distribute unit weight evenly and prevent noise and vibration (See fig.7).

NOTE: Do not block drain openings shown in fig.7.

- If unit must be elevated because of anticipated snow fall, secure unit and elevating stand such that unit and/or stand will not tip over or fall off.

NOTE: To tie down unit, see 3.9.

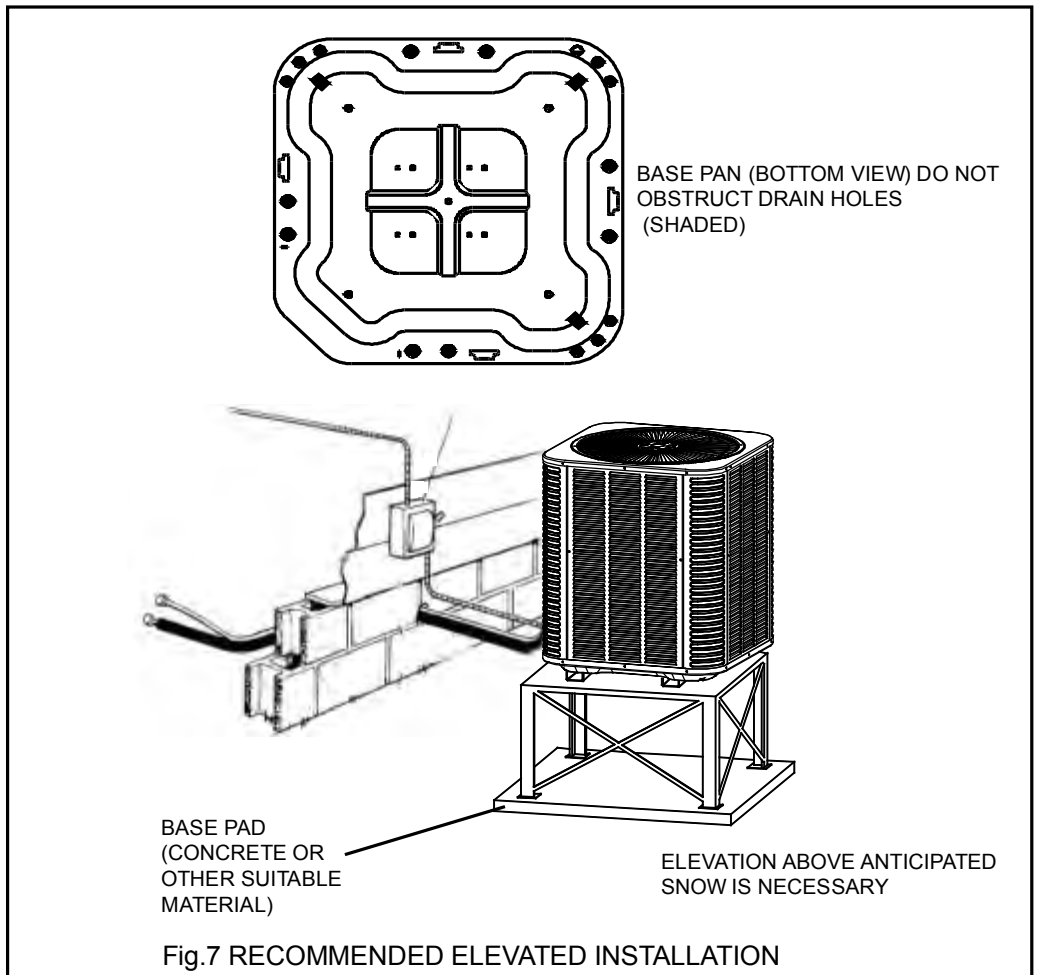

3.9 FACTORY-PREFERRED TIE-DOWN METHOD

Step 1: Prior to installing clear pad of debris.

IMPORTANT

Then cement pad must be made of HVAC-approved materials and must be the proper thickness to accommodate fasteners.

Step 2: Center and level unit onto pad.

Step 3: Using L-shaped bracket to locate holes on concrete and drill pilot holes which is at least 1/4" deeper than fastener being used.

IMPORTANT

Self drilling screws to base pan should not exceed 3/8" long to avoid damaging coil.

Step 4: Using conventional practices to install brackets, tighten concrete fasteners and self-tapping screws (See Fig.8).

- NOTE:**
1. One bracket for each side. For extra stability, 2 brackets for each side.
 2. Do not over-tighten the concrete fastener to avoid weakening the concrete.

IMPORTANT NOTE:

These instructions are intended to provide a method to tie-down system to cement slab as a securing procedure for high wind areas. It is recommended to check Local Codes for tie-down methods and protocols.

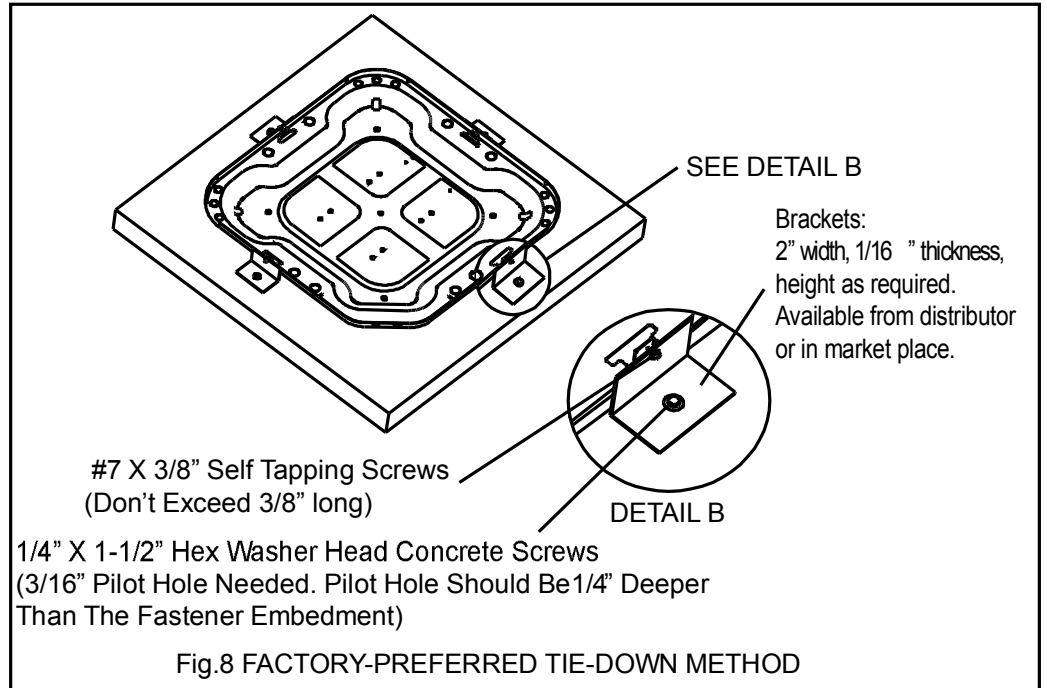

3.10 REMOVING THE TOP PANEL AND MOTOR

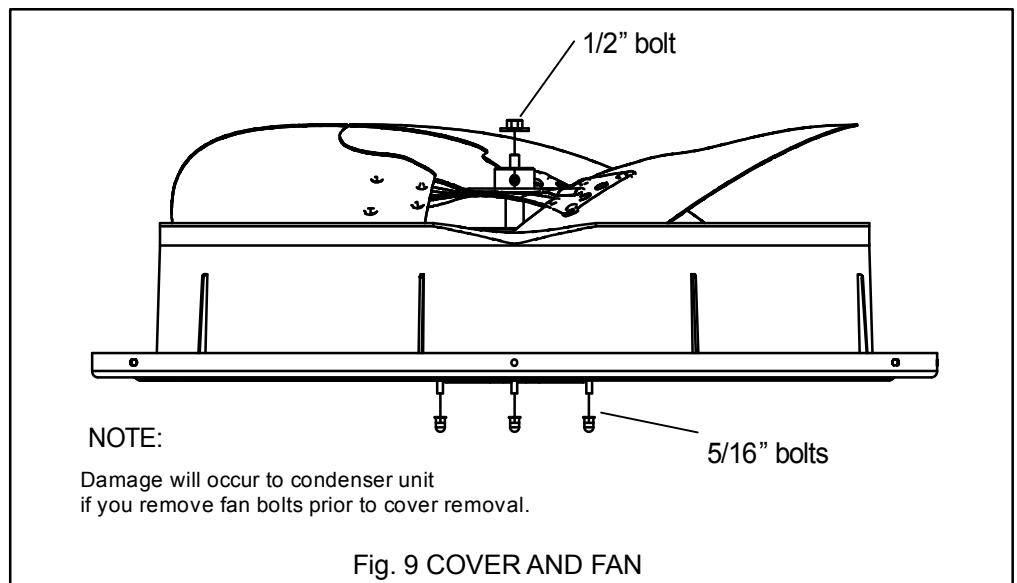

When motor requires changing follow the steps below:

Step 1: Go into electrical panel, disconnect motor power lines.

IMPORTANT NOTE

Disconnect main power to unit. Severe burns and electrical shock will occur if you do not disconnect main power.

Step 2: Remove cover (be careful of motor wires)

Step 3: Be sure to place fan cover unit on the ground as indicated in Fig. 9

IMPROTANT NOTE

Do not place or lean fan blades on ground or against surface.

Step 4: Remove fan motor by removing 5/16" bolts from cover.

Step 5: Remove fan blade from motor by removing 1/2" bolt and place fan on the ground.

Step 6: Reverse removal process to reinstall the fan and motor.

IMPROTANT NOTE

When connecting motor wires be sure to check motor direction.

4.0 ELECTRICAL CONNECTIONS

4.1 GENERAL INFORMATION & GROUNDING

Check the electrical supply to be sure that it meets the values specified on the unit nameplate and wiring label.

Power wiring, control (low voltage) wiring, disconnect switches and over current protection must be supplied by the installer. Wire size should be sized per requirements.



CAUTION

All field wiring must USE COPPER CONDUCTORS ONLY and be in accordance with Local, National Fire, Safety & Electrical Codes. This unit must be grounded with a separate ground wire in accordance with the above codes.

The complete connection diagram and schematic wiring label is located on the inside surface of the unit service access panel and this instruction.

4.2 FIELD CONNECTIONS POWER WIRING

1. Install the proper size weatherproof disconnect switch outdoors and within sight of the unit.
2. Remove the screws at the side of the corner cover. Slide corner cover down and remove from unit. See Fig. 10.
3. Run power wiring from the disconnect switch to the unit.
4. Route wires from disconnect through power wiring opening provided and into the unit control box.

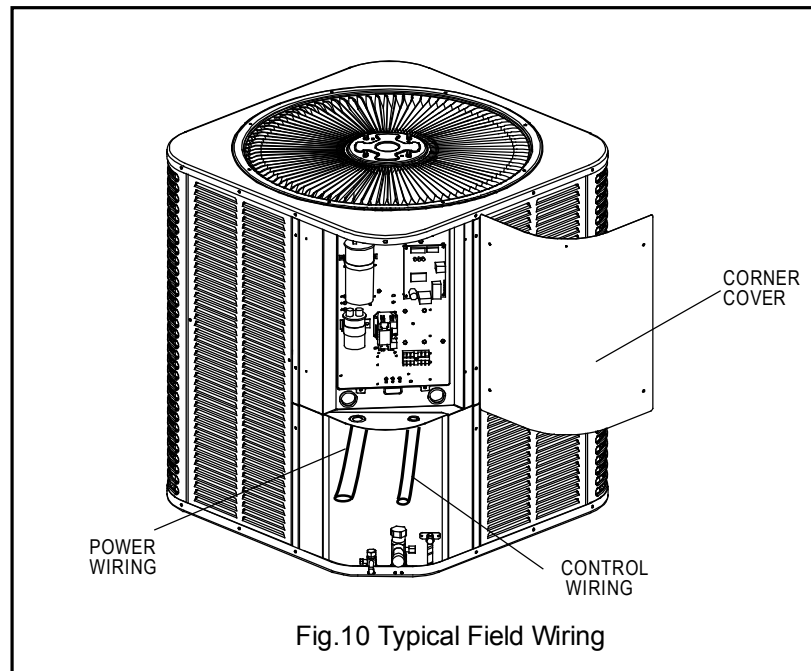

Fig.10 Typical Field Wiring

5. Install the proper size time-delay fuses or circuit breaker, and make the power supply connections.
6. Energize the crankcase heater if equipped to save time by preheating the compressor oil while the remaining installation is completed.

NOTE: When changing the motor, remove top cover first.

5.0 EVACUATION

It will be necessary to evacuate the system to 500 microns or less. If a leak is suspected, leak test with dry nitrogen to locate the leak. Repair the leak and test again. To verify that the system has no leaks, simply close the valve to the vacuum pump suction to isolate the pump and hold the system under vacuum. Watch the micron gauge for a few minutes. If the micron gauge indicates a steady and continuous rise, it's an indication of a leak. If the gauge shows a rise, then levels off after a few minutes and remains fairly constant, it's an indication that the system is leak free but still contains moisture and may require further evacuation if the reading is above 500 microns.

6.0 INTERCONNECTING TUBING

6.1 VAPOR AND LIQUID LINES

Keep all lines sealed until connection is made.

Make connections at the indoor coil first.

Refer to Line Size Information in Tables 2 and 3 for correct size and multipliers to be used to determine capacity for various vapor line diameters and lengths of run. The losses due to the lines being exposed to outdoor conditions are not included.

The factory refrigerant charge in the outdoor unit is sufficient for 25 feet of interconnecting lines. The factory refrigerant charge in the outdoor unit is sufficient for the unit and 25 feet of standard size interconnecting liquid and vapor lines. For different lengths, adjust the charge as indicated below.

1/4" ± .3 oz. per foot

5/16" ± .4 oz. per foot

3/8" ± .6 oz. per foot

1/2" ± 1.2 oz. per foot

6.2 MAXIMUM LENGTH OF LINES

The maximum length of interconnecting line is 150 feet.

Always use the shortest length possible with a minimum number of bends. Additional compressor oil is not required for any length up to 150 feet.

NOTE: Excessively long refrigerant lines cause loss of equipment capacity.

6.3 VERTICAL SEPARATION

Keep the vertical separation to a minimum. Use the following guidelines when installing the unit:

1. DO NOT exceed the vertical separations as indicated on Table 3.
2. It is recommended to use the smallest liquid line size permitted to minimize system charge which will maximize compressor reliability.
3. Table 3 may be used for sizing horizontal runs.

7.0 SYSTEM OPERATION

7.1 COMPRESSOR CRANKCASE HEATER (CCH)

Refrigerant migration during the off cycle can result in a noisy start up. Add a crankcase heater to minimize refrigeration migration, and to help eliminate any start up noise or bearing "wash out".

All heaters are located on the lower half of the compressor shell. Its purpose is to drive refrigerant from the compressor shell during long off cycles, thus preventing damage to the compressor during start-up.

At initial start-up or after extended shutdown periods, make sure the heater is energized for at least 12 hours before the compressor is started. (Disconnect switch on and wall thermostat off.)

■ The crankcase heating belt's drive-up conditions:

When outdoor temp. is < 37.4 ° F, compressor will pause for no less than 3 hours or be plugged in power at such kind of ambient temperature.

■ Crankcase heating belt's shut-down conditions:

When outdoor temp. is > 44.6 ° F or the compressor start up, the crankcase heating belt will be shut down.

TABLE 2: SUCTION LINE LENGTH/SIZE VS CAPACITY MULTIPLIER(R410A)

Unit Size		1 1/2 Ton	2 Ton	2 1/2 Ton	3 Ton	3 1/2 Ton	4 Ton	5 Ton
Suction Line Connection Size		3/4" I.D.	3/4" I.D.	3/4" I.D.	3/4" I.D.	3/4" I.D.	7/8" I.D.	7/8" I.D.
Suction Line Run—Feet		5/8 Opt.	5/8 Opt.	5/8 Opt.	5/8 Opt.	5/8 Opt.	3/4 Opt.	1 1/8 Opt.
		3/4* Std.	3/4* Std.	3/4* Std.	3/4* Std.	3/4* Std.	7/8* Std.	7/8* Std.
25'	Optional	1.00	1.00	1.00	1.00	1.00	1.00	1.00
	Standard	1.00	1.00	1.00	1.00	1.00	1.00	0.99
50'	Optional	0.97	0.97	0.97	0.97	0.98	0.98	0.99
	Standard	0.98	0.98	0.98	0.99	0.98	0.98	0.98
100'	Optional	0.94	0.94	0.94	0.94	0.95	0.95	0.98
	Standard	0.95	0.95	0.96	0.97	0.97	0.97	0.94
150'	Optional	0.90	0.90	0.90	0.90	0.91	0.92	0.97
	Standard	0.92	0.92	0.93	0.96	0.96	0.96	0.90

NOTES:

* Standard size

Using suction line larger than shown in chart will result in poor oil return and is not recommended.

TABLE 3 : LIQUID LINE SIZING (R-410A)

System Capacity	Line Size Connection Size (Inch I.D.)	Compressor Type	Line Size Connection And Line Size (Inch I.D.)	Liquid Line Size Outdoor unit above or below indoor coil (Heat Pumps Only)					
				Total Equivalent Length - Feet					
				25	50	75	100	125	150
				Maximum Vertical Separation - Feet					
1 1/2 Ton	3/8"	Scroll	1/4	25	40	25	9	N/A	N/A
			5/16	25	50	62	58	53	49
			3/8*	25	50	75	72	70	68
2 Ton	3/8"	Scroll	1/4	23	N/A	N/A	N/A	N/A	N/A
			5/16	25	36	29	23	16	9
			3/8*	25	50	72	70	68	65
2 1/2 Ton	3/8"	Scroll	1/4	25	N/A	N/A	N/A	N/A	N/A
			5/16	25	49	38	27	17	6
			3/8*	25	50	68	65	62	58
3 Ton	3/8"	Scroll	5/16	25	50	37	22	7	N/A
			3/8*	25	50	68	63	58	53
3 1/2 Ton	3/8"	Scroll	5/16	25	23	4	N/A	N/A	N/A
			3/8*	25	50	43	36	30	24
4 Ton	3/8"	Scroll	3/8*	25	46	38	30	22	15
			1/2	25	50	56	55	53	52
5 Ton	3/8"	Scroll	3/8*	25	50	56	44	32	20
			1/2	25	50	75	81	79	76

NOTES:

* Standard line size

N/A Application not recommended.

TABLE 4 : PISTON SIZE/TXV VALVE MODEL OF INDOOR UNIT:

Condensing Unit	Air Handler	Piston Size/TXV Valve Model	SEER	Condensing Unit	Air Handler	Piston Size/TXV Valve Model	SEER	HS PF
ADA2-18-410	HD2-18+TXV	TR6-3TON	14	ADH2-18-410	HD2-18+TXV	TR6-3TONB	14	7.8
ADA2-24-410	HD2-24+TXV	TR6-3TONB	14	ADH2-24-410	HD2-24+TXV	TR6-3TONB	14	7.8
	HD2-25	056	14		HD2-25	057	14	7.8
ADA2-30-410	HD2-31	067	14	ADH2-30-410	HD2-31	067	14	8.3
MAH-36-410	HD2-36	073	13	MHH-36-410	HD2-36	068	13	8.2
	AC3036A	070	13		AC3036A	071	13	7.7
	AC3036B	070	13		AC3036B	066	13	7.7
	AC3036C	070	13		AC3036C	068	13	7.7
	HD2-36+TXV	TR6-4TON	14		HD2-36+TXV	TR6-4TON	14	8.3
MAH-42-410	HD2-42	077	13	MHH-42-410	HD2-42	080	13	8.2
	AC3642B	072	13		AC3642B	079	13	7.7
	AC3642C	072	13		AC3642C	078	13	7.7
	AC3642D	072	13		AC3642D	080	13	7.7
	HD2-42+TXV	TR6-4TON	14		HD2-42+TXV	TR6-4TON	14	8.3
	HD2-43	080	14		HD2-43	080	14	8.3
MAH-48-410	HD2-48	105	13	MHH-48-410	HD2-48	090	13	8.2
	AC4248B	088	13		AC4248B	088	13	7.7
	AC4248C	088	13		AC4248C	092	13	7.7
	AC4248D	088	13		AC4248D	096	13	7.7
	HD2-48+TXV	TR6-5TON	14		HD2-48+TXV	TR6-5TON	14	8.3
ADA2-60-410	HD2-60	102	14	ADH2-60-410	HD2-60+TXV	TR6-6TON	14	8.3

7.2 PROTECTION FUNCTION INTRODUCTION

- **Sensor T3 (condenser pipe temperature) and T4 (outdoor ambient temperature)**
When open-circuit, compressor, outdoor fan motor and reverse valve will be OFF.
When T4 is $< 5^{\circ}\text{F}$, the compressor will stop. If the electrical heater kit is installed in the indoor unit, the outdoor unit provides the signal when it is to work.
When T4 is $> 10.4^{\circ}\text{F}$, the compressor will restart.
- **Discharge temperature protection (Heat pump only)**
When discharge temp. is $> 275^{\circ}\text{F}$, the compressor will stop.
When discharge temp. is $< 194^{\circ}\text{F}$, the compressor will restart.
- **High perssure protection (Heat pump only)**
When high pressure is > 638 PSIG, the compressor and the outdoor fan motor will stop.
When high pressure is < 464 PSIG, the compressor and the outdoor fan motor will restart (3 minutes delay necessary).
- **Low pressure protection (Heat pump only)**
Low pressure is < 21 PSIG, the compressor and the outdoor fan motor will stop.
Low pressure is > 44 PSIG, the compressor and the outdoor fan motor will restart (3 minutes delay necessary).
In stand-by status, the compressor will not start in low pressure protection.
Within 30 mins, if 4 protection cycles occurs, system will restore after power cut-down.

7.3 DEFROST MODE INTRODUCTION

- **Start-up conditions of defrost mode:**
When JUMP switch is set to "1" (See in Fig 11), the mode will start up in either of the two following conditions:
 1. Compressor operating, when T4 is $> 28.4^{\circ}\text{F}$ and T3 is $< 32^{\circ}\text{F}$ last for 40 minutes;
 2. Compressor operating, when T4 is $< 28.4^{\circ}\text{F}$ and T3 is $< 32^{\circ}\text{F}$ last for 50 minutes.When JUMP switch is set to "0":
Compressor operating, when T3 is $< 32^{\circ}\text{F}$ last for 30 minutes.
- **Shut-down conditions of defrost mode:**
The mode will shut down in either of the two following conditions:
 1. The defrosted time lasting for 10 minutes;
 2. T3 is $\geq 77^{\circ}\text{F}$.

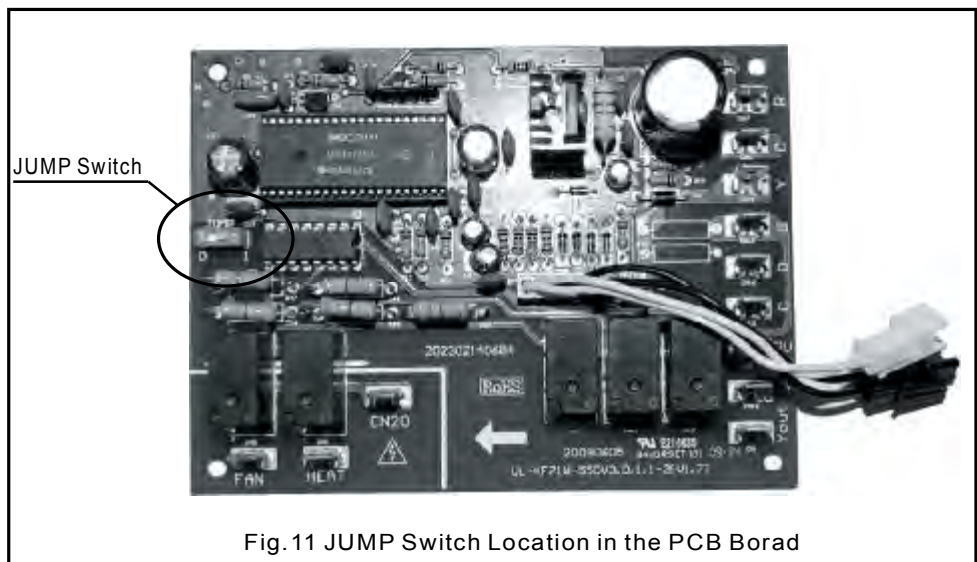

8.0.CHECKING REFRIGERANT CHARGE

Charge for all systems should be checked against the Charging Chart inside the access panel cover.

IMPORTANT: Do not operate the compressor without charge in system. Addition of R-410A will raise pressures (vapor, liquid and discharge).

If adding R-410A raises both vapor pressure and temperature, the unit is over - charged.

IMPORTANT: Use industry -approved charging methods to ensure proper system charge.

8.1 CHARGING BY LIQUID PRESSURE

The liquid pressure method is used for charging systems in the cooling and heating mode. The service port on the liquid (small valve) and suction (large valve) is used for this purpose.

Verify that the outdoor unit is running and the indoor air mover is delivering the maximum airflow for this system size. Read and record the outdoor ambient temperature. Read and record the liquid and suction pressures at the ports on the liquid and suction valves.

If refrigerant lines are sized using the nameplate charge, the correct liquid pressure is found at the intersection of the suction pressure and the outdoor ambient.

1. Remove refrigerant charge if the liquid pressure is above the chart value.
2. Add refrigerant charge if the liquid pressure is below the chart value.

8.2 CHARGING BY WEIGHT

For a new installation, evacuation of interconnecting tubing and indoor coil is adequate; otherwise, evacuate the entire system. Note that charge value includes charge required for 25 ft. of standard size interconnecting liquid line. Calculate actual charge required with installed liquid line size and length using:

1/4" O.D. = .3 oz./ft.

5/16" O.D. = .4 oz./ft

3/8" O.D. = .6 oz./ft

1/2" O.D. = 1.2 oz./ft

With an accurate scale (+/-1 oz.) or volumetric charging device, adjust charge difference between that shown on the unit data plate and that calculated for the new system installation. If the entire system has been evacuated, add the total calculated charge.

8.3 FINAL LEAK TESTING

After the unit has been properly evacuated and charged, a halogen leak detector should be used to detect leaks in the system. All piping within the condensing unit, evaporator, and interconnecting tubing should be checked for leaks. If a leak is detected, the refrigerant should be recovered before repairing the leak. The Clean Air Act prohibits releasing refrigerant into the atmosphere.

TABLE 5: REFRIGERANT CHARGE FOR A/C SYSTEM.

Cooling Mode		Cooling Charge Chart 1.5 TON (FOR HD2-18+TXV)												
		Outdoor Ambient Temperature (°F)												
		55	60	65	70	75	80	85	90	95	100	105	110	115
Vapor Pressure at Large Service Valve (psig)	165	236	253	270	291	310	334	355	378	401	425	455	484	
	161	234	251	268	289	308	332	353	376	399	422	452	482	
	157	232	249	266	287	306	329	351	374	397	420	450	479	
	153	230	247	264	285	304	327	349	372	395	418	448	477	
	149	211	228	245	262	283	302	325	347	370	393	417	446	475
	145	209	226	243	260	281	300	323	345	368	391	415	444	473
	141	207	224	241	258	279	298	321	343	366	388	413	442	471
	137	205	222	239	256	277	296	319	341	364	387	411	440	469
	133	203	220	237	254	275	294	317	339	362	385	409	438	467
	129	201	218	235	252	273	292	315	337	360	382	407	435	464
	125	199	216	233	250	271	290	313	335	358	380	404	433	461
	121	197	214	231	248	269	288	311	333	355	378	402	430	459
	117	195	212	229	246	267	286	309	331	353	376	400	428	456
	113	193	210	227	244	265	284	307	329	351	374	397	425	453
	109	191	208	225	242	263	282	305	327	349	371	394	421	449
105	189	206	223	240	261	280	303	325	347	369	392	418	446	
Cooling Mode		Cooling Charge Chart 2 TON (FOR HD2-29)												
		Outdoor Ambient Temperature (°F)												
		55	60	65	70	75	80	85	90	95	100	105	110	115
Vapor Pressure at Large Service Valve (psig)	165	256	276	293	312	332	351	372	396	417	441	467	494	
	161	254	273	290	310	329	328	368	394	415	438	464	491	
	157	252	270	287	307	326	325	365	392	412	436	461	489	
	153	251	268	285	305	323	342	362	389	409	434	458	486	
	149	234	249	266	283	303	320	339	360	385	408	432	458	484
	145	232	248	264	281	300	318	337	358	382	404	428	454	481
	141	230	246	262	279	298	316	335	356	380	402	426	452	479
	137	229	245	260	277	296	314	333	354	378	400	425	450	477
	133	227	243	258	275	294	312	331	352	376	398	422	448	474
	129	225	241	256	273	291	310	329	350	374	396	419	445	471
	125	222	239	254	271	289	307	327	348	371	393	416	443	467
	121	219	236	252	269	286	305	325	346	369	390	413	439	463
	117	216	233	250	267	284	303	323	344	367	387	410	436	461
	113	214	231	248	265	283	300	320	342	366	383	407	432	456
	109	211	229	246	263	281	298	318	340	362	380	404	429	454
105	209	227	244	261	279	296	316	337	358	377	401	426	451	
Cooling Mode		Cooling Charge Chart 3 TON (FOR HD2-36)												
		Outdoor Ambient Temperature (°F)												
		55	60	65	70	75	80	85	90	95	100	105	110	115
Vapor Pressure at Large Service Valve (psig)	165	236	253	270	305	327	350	371	395	416	441	471	503	
	161	234	251	268	303	324	327	367	393	414	438	468	500	
	157	232	249	266	300	321	324	364	391	411	436	465	498	
	153	230	247	264	298	318	341	361	386	408	434	462	495	
	149	211	228	245	262	296	315	338	359	384	405	432	460	493
	145	209	226	243	260	293	313	336	357	381	403	430	458	490
	141	207	224	241	258	291	311	334	355	379	401	428	456	488
	137	205	222	239	256	289	309	332	353	377	399	425	454	486
	133	203	220	237	254	287	307	330	351	375	397	422	452	483
	129	201	218	235	252	284	305	328	349	373	395	419	449	480
	125	199	216	233	250	282	302	326	347	370	392	416	447	476
	121	197	214	231	248	279	300	324	345	368	389	413	443	472
	117	195	212	229	246	277	298	322	343	366	386	410	440	470
	113	193	210	227	244	275	295	319	341	365	382	407	436	465
	109	191	208	225	242	274	293	317	339	361	379	404	433	463
105	189	206	223	240	272	291	315	336	357	376	401	430	460	
Cooling Mode		Cooling Charge Chart 2 TON (FOR HD2-31)												
		Outdoor Ambient Temperature (°F)												
		55	60	65	70	75	80	85	90	95	100	105	110	115
Vapor Pressure at Large Service Valve (psig)	165	257	274	291	309	328	350	372	394	416	440	467		
	161	255	272	289	307	326	348	370	392	414	437	464		
	157	253	270	287	305	324	346	368	390	412	435	462		
	153	234	251	268	285	303	321	343	365	387	409	433	460	
	149	232	249	266	283	301	319	341	363	385	407	431	458	
	145	230	247	264	281	298	316	338	360	382	404	426	456	
	141	211	228	245	262	279	296	313	335	357	379	401	424	454
	137	209	226	243	260	277	294	311	333	355	377	399	421	452
	133	207	224	241	258	275	292	309	331	353	375	397	420	450
	129	205	222	239	256	273	290	308	328	350	372	394	417	448
	125	203	220	237	254	271	288	304	326	348	370	392	415	444
	121	201	218	235	252	269	286	302	324	346	368	390	413	442
	117	199	216	233	250	267	284	300	322	344	366	388	410	439
	113	197	214	231	248	265	282	298	320	342	364	386	408	437
	109	193	211	228	245	262	279	297	319	341	363	385	407	435
105	191	208	225	242	259	276	295	317	339	361	383	405	433	
Cooling Mode		Cooling Charge Chart 3 TON (FOR HD2-36+TXV)												
		Outdoor Ambient Temperature (°F)												
		55	60	65	70	75	80	85	90	95	100	105	110	115
Vapor Pressure at Large Service Valve (psig)	165	255	273	292	315	338	362	387	439	491	514	538		
	161	253	271	290	313	336	360	385	437	489	512	536		
	157	251	269	288	311	334	357	382	435	487	510	534		
	153	230	249	267	286	309	332	357	410	462	485	508	532	
	149	228	247	265	284	307	329	353	406	458	481	505	530	
	145	226	245	263	282	305	327	351	404	456	479	503	527	
	141	203	221	239	257	283	310	332	353	375	397	420	445	
	137	201	219	237	255	273	291	307	329	351	373	395	418	443
	133	199	217	235	253	271	289	305	327	349	371	393	415	440
	129	197	215	232	250	268	286	303	324	347	368	390	412	437
	125	195	212	229	247	265	283	301	322	344	365	387	409	433
	121	193	210	227	244	262	280	299	319	341	362	384	405	428
	117	191	208	225	242	259	277	296	317	338	359	380	401	424
	113	189	206	223	240	257	274	294	315	335	356	377	397	419
	109	187	204	221	238	255	272	292	313	332	353	373	394	415
105	185	202	219	236	253	270	290	310	330	350	370	390	412	

Cooling Mode		Cooling Charge Chart 3.5 TON (FOR HD2-42)												
		Outdoor Ambient Temperature (°F)												
		55	60	65	70	75	80	85	90	95	100	105	110	115
Vapor Pressure at Large Service Valve (psig)	165			267	282	295	333	337	363	407	423	449	475	502
	161			265	279	293	331	335	361	405	421	447	473	500
	157			263	277	291	329	332	359	403	419	444	470	495
	153	248	261	274	289	327	330	357	401	417	442	468	493	
	149	245	258	272	287	325	328	355	399	415	440	465	490	
	145	243	256	270	285	323	326	353	396	412	437	462	487	
	141	230	241	254	268	283	321	324	351	394	409	433	458	485
	137	227	239	252	266	281	319	322	349	391	406	430	454	482
	133	225	236	250	264	278	317	320	347	389	403	427	451	478
	129	222	233	248	261	275	314	317	344	387	401	424	448	475
	125	219	229	245	258	273	311	314	341	383	398	420	447	472
	121	215	225	241	255	270	308	311	338	381	396	418	445	469
	117	211	222	237	252	266	306	311	338	380	394	416	442	466
	113	207	219	235	250	264	304	309	336	378	391	414	438	462
	109	203	216	232	246	264	302	307	333	375	387	410	434	459
105	201	213	229	245	262	300	304	330	372	384	406	430	456	

Cooling Mode		Cooling Charge Chart 3.5 TON (FOR HD2-42+TXV)												
		Outdoor Ambient Temperature (°F)												
		55	60	65	70	75	80	85	90	95	100	105	110	115
Vapor Pressure at Large Service Valve (psig)	165			255	273	288	308	328	351	377	423	479	505	532
	161			253	270	286	306	326	349	375	421	477	503	530
	157			251	268	284	304	323	347	373	419	474	500	526
	153	233	249	265	282	302	321	345	371	417	472	498	523	
	149	230	246	263	280	300	319	343	369	415	470	495	520	
	145	228	244	261	278	298	317	341	366	412	467	492	517	
	141	210	226	242	259	276	296	315	339	364	409	463	488	515
	137	207	224	240	257	274	294	313	337	361	406	460	484	512
	133	205	221	238	255	271	292	311	335	359	403	457	481	508
	129	202	218	236	252	269	289	308	332	357	401	453	479	505
	125	198	214	233	249	266	286	307	331	355	399	450	477	502
	121	195	210	229	246	263	283	304	328	353	396	448	475	499
	117	191	207	225	243	261	281	302	326	350	394	446	472	496
	113	187	204	223	241	259	279	300	324	348	391	444	468	492
	109	183	201	220	239	257	277	298	321	345	387	440	464	489
105	181	198	217	236	255	275	295	318	342	384	436	460	486	

Cooling Mode		Cooling Charge Chart 4 TON (FOR HD2-48)												
		Outdoor Ambient Temperature (°F)												
		55	60	65	70	75	80	85	90	95	100	105	110	115
Vapor Pressure at Large Service Valve (psig)	165			253	270	287	304	322	343	369	391	414	439	466
	161			251	268	285	302	320	343	368	389	412	437	463
	157			249	266	283	300	318	341	364	387	410	435	460
	153	230	247	264	281	298	316	339	362	385	408	433	458	
	149	228	245	262	279	296	314	337	360	383	406	430	456	
	145	226	243	260	277	294	312	334	358	380	403	427	453	
	141	207	224	241	258	275	292	310	332	355	377	400	423	450
	137	205	222	239	256	273	290	308	330	353	375	397	419	447
	133	203	220	237	254	271	288	306	328	350	372	394	416	444
	129	200	218	235	251	268	285	304	325	347	368	390	411	438
	125	197	215	232	248	265	283	302	323	343	364	386	406	432
	121	195	213	229	245	261	281	301	324	343	361	382	402	428
	117	192	209	226	243	260	279	298	318	338	358	378	398	422
	113	190	207	223	241	257	277	296	316	336	356	376	396	418
	109	188	205	221	238	255	275	294	314	334	354	374	394	416
105	185	202	219	236	253	273	292	312	332	352	372	392	414	

Cooling Mode		Cooling Charge Chart 4 TON (FOR HD2-48+TXV)												
		Outdoor Ambient Temperature (°F)												
		55	60	65	70	75	80	85	90	95	100	105	110	115
Vapor Pressure at Large Service Valve (psig)	165			253	270	287	304	322	343	369	391	414	439	466
	161			251	268	285	302	320	343	368	389	412	437	463
	157			249	266	283	300	318	341	364	387	410	435	460
	153	230	247	264	281	298	316	339	362	385	408	433	458	
	149	228	245	262	279	296	314	337	360	383	406	430	456	
	145	226	243	260	277	294	312	334	358	380	403	427	453	
	141	207	224	241	258	275	292	310	332	355	377	400	423	450
	137	205	222	239	256	273	290	308	330	353	375	397	419	447
	133	203	220	237	254	271	288	306	328	350	372	394	416	444
	129	200	218	235	251	268	285	304	325	347	368	390	411	438
	125	197	215	232	248	265	283	302	323	343	364	386	406	432
	121	195	213	229	245	261	281	301	324	343	361	382	402	428
	117	192	209	226	243	260	279	298	318	338	358	378	398	422
	113	190	207	223	241	257	277	296	316	336	356	376	396	418
	109	188	205	221	238	255	275	294	314	334	354	374	394	416
105	185	202	219	236	253	273	292	312	332	352	372	392	414	

Cooling Mode		Cooling Charge Chart 5 TON (FOR HD2-60)												
		Outdoor Ambient Temperature (°F)												
		55	60	65	70	75	80	85	90	95	100	105	110	115
Vapor Pressure at Large Service Valve (psig)	165			310	329	333	337	341	352	374	395	418	440	473
	161			316	321	326	330	335	347	369	390	413	436	470
	157			322	314	316	323	329	343	366	389	413	436	470
	153	279	280	289	303	323	340	368	389	410	434	458		
	149	270	280	288	299	311	322	336	360	383	408	432	467	
	145	261	271	280	294	308	322	334	357	379	404	429	464	
	141	239	250	261	272	287	302	317	331	355	379	404	428	463
	137	227	237	248	259	277	296	315	330	354	379	403	427	461
	133	213	228	243	257	276	295	314	328	352	376	400	425	459
	129	203	220	237	254	273	293	313	327	351	376	398	421	454
	125	202	218	234	250	271	291	312	326	350	374	397	420	452
	121	201	217	232	248	269	289	309	323	347	371	392	414	446
	117	200	216	232	248	268	289	309	322	346	369	390	413	445
	113	197	214	230	247	270	293	316	324	343	362	383	405	436
	109	195	211	227	243	263	283	304	316	337	359	380	401	431
105	190	207	225	242	262	282	302	313	334	355	376	397	427	

Heating Mode		Heating Charge Chart 1.5 TON (FOR HD2-18+TXV)											
		Indoor Dry Bulb Temperature (°F)											
		60	62	64	66	68	70	72	74	76	78	80	82
Pressure after Suction Valve-Subcool to Compressor (psig)	135	332	339	346	353	360	367	375	382	389	397	405	414
	128	320	327	334	341	348	355	363	370	377	384	392	400
	121	309	316	323	330	337	344	351	358	365	372	380	388
	114	297	304	311	318	325	333	341	348	355	362	369	375
	107	289	296	303	310	317	324	331	338	345	352	359	364
	100	278	285	292	299	306	313	320	327	334	341	348	353
	93	269	276	283	290	297	304	310	317	323	329	335	342
	86	259	266	273	280	287	294	300	306	312	318	324	330
	79	250	257	264	271	278	284	290	296	302	308	314	321
	72	240	246	253	259	266	272	278	284	290	296	301	308
	65	231	238	245	252	259	266	272	278	284	290	296	302
	58	224	231	238	245	252	259	266	272	278	284	290	296
	51	218	224	231	238	245	252	259	266	272	278	284	290
	44	212	218	224	231	238	245	252	259	266	272		

Cooling Mode		Cooling Charge Chart 3 TON(FOR HD2-36)												
		Outdoor Ambient Temperature(°F)												
		55	60	65	70	75	80	85	90	95	100	105	110	115
Vapor Pressure at Large Service Valve(psig)	165			251	269	287	305	323	345	367	389	411	434	458
	161			249	267	285	303	321	343	365	387	409	432	456
	157			247	265	283	301	319	340	362	385	407	430	454
	153		227	245	263	281	299	317	338	360	382	405	428	452
	149		225	243	261	279	297	314	336	358	380	403	426	450
	145		223	241	259	277	295	312	334	356	378	400	423	447
	141	203	221	239	257	275	293	310	332	353	375	397	420	445
	137	201	219	237	255	273	291	307	329	351	373	395	418	443
	133	199	217	235	253	271	289	305	327	349	371	393	415	440
	129	197	215	233	251	269	287	303	324	347	368	390	412	437
	125	195	213	231	249	267	285	301	322	344	365	387	409	433
	121	193	211	229	247	265	283	299	319	341	362	384	405	428
	117	191	208	226	244	262	280	296	317	338	359	380	401	424
	113	189	206	224	242	260	278	294	315	335	356	377	397	419
	109	187	204	222	240	258	276	292	313	333	353	373	394	415
105	185	202	219	236	253	270	290	310	330	350	370	390	412	

Heating Mode		Heating Charge Chart 3 TON(FOR HD2-36)											
		Indoor Dry Bulb Temperature(°F)											
		60	62	64	66	68	70	72	74	76	78	80	82
Pressure after Switchover Valve-Suction to Compressor(psig)	135	294	301	308	315	322	329	336	343	350	357	364	371
	128	288	295	302	309	316	323	330	337	344	351	358	365
	121	282	289	296	303	310	317	324	331	338	345	352	359
	114	276	283	290	297	304	311	318	325	332	339	346	353
	107	270	277	284	291	298	305	312	319	326	333	340	347
	100	264	271	278	285	292	299	306	313	320	327	334	341
	93	258	265	272	279	286	293	300	307	314	321	328	335
	86	251	258	265	272	279	286	293	300	307	314	321	328
	79	244	251	258	265	272	279	286	293	300	307	314	321
	72	238	245	252	259	266	273	280	287	294	301	308	315
	65	231	238	245	252	259	266	273	280	287	294	301	308
	58					254	260	267	274	281	288	295	302
	51						255	262	269	276	283	289	297
	44							256	263	270	278	284	292
	37								258	264	274	279	288

Cooling Mode		Cooling Charge Chart 3 TON(FOR HD2-36+TXV)												
		Outdoor Ambient Temperature(°F)												
		55	60	65	70	75	80	85	90	95	100	105	110	115
Vapor Pressure at Large Service Valve(psig)	165			255	273	292	315	338	362	387	439	491	514	538
	161			253	271	290	313	336	360	385	437	489	512	536
	157			251	269	288	311	334	357	382	435	487	510	534
	153		230	249	267	286	309	332	355	380	432	485	508	532
	149		228	247	265	284	307	329	353	378	430	483	506	530
	145		226	245	263	282	305	327	351	376	428	480	503	527
	141	173	224	243	261	280	303	325	349	373	425	477	500	525
	137	171	222	241	259	278	300	322	346	371	423	475	498	523
	133	169	220	239	257	276	299	320	344	369	421	473	496	521
	129	167	218	236	254	273	296	318	341	367	418	470	492	517
	125	165	215	233	251	270	293	316	339	364	415	467	489	513
	121	163	213	231	248	267	290	314	336	361	412	464	485	508
	117	161	211	229	246	264	287	311	334	358	409	460	481	504
	113	159	209	227	244	262	284	309	332	355	406	457	477	499
	109	157	207	225	242	260	282	307	330	352	403	453	474	495
105	155	205	223	240	258	280	305	327	350	400	450	470	492	

Heating Mode		Heating Charge Chart 3 TON(FOR HD2-36+TXV)											
		Indoor Dry Bulb Temperature(°F)											
		60	62	64	66	68	70	72	74	76	78	80	82
Pressure after Switchover Valve-Suction to Compressor(psig)	135	294	301	308	315	322	329	336	343	350	357	364	371
	128	288	295	302	309	316	323	330	337	344	351	358	365
	121	282	289	296	303	310	317	324	331	338	345	352	359
	114	276	283	290	297	304	311	318	325	332	339	346	353
	107	270	277	284	291	298	305	312	319	326	333	340	347
	100	264	271	278	285	292	299	306	313	320	327	334	341
	93	258	265	272	279	286	293	300	307	314	321	328	335
	86	251	258	265	272	279	286	293	300	307	314	321	328
	79	244	251	258	265	272	279	286	293	300	307	314	321
	72	238	245	252	259	266	273	280	287	294	301	308	315
	65	231	238	245	252	259	266	273	280	287	294	301	308
	58					254	260	267	274	281	288	295	302
	51						255	262	269	276	283	289	297
	44							256	263	270	278	284	292
	37								258	264	274	279	288

Cooling Mode		Cooling Charge Chart 3.5 TON (FOR HD2-42)												
		Outdoor Ambient Temperature(°F)												
		55	60	65	70	75	80	85	90	95	100	105	110	115
Vapor Pressure at Large Service Valve(psig)	165			267	282	295	333	337	363	407	423	449	475	502
	161			265	279	293	331	335	361	405	421	447	473	500
	157			263	277	291	329	333	359	403	419	445	471	495
	153		248	261	274	289	327	330	357	401	417	442	468	493
	149		245	258	272	287	325	328	355	399	415	440	465	490
	145		243	256	270	285	323	326	353	396	412	437	462	487
	141	230	241	254	268	283	321	324	351	394	409	433	458	485
	137	227	239	252	266	281	319	322	349	391	406	430	454	482
	133	225	236	250	264	278	317	320	347	389	403	427	451	478
	129	222	233	248	261	276	314	318	345	387	401	423	447	475
	125	219	229	245	258	273	311	316	343	385	399	420	447	472
	121	215	225	241	255	270	308	313	340	383	396	418	445	469
	117	211	222	237	252	268	306	311	338	380	394	416	442	466
	113	207	219	235	250	266	304	309	336	378	391	414	438	462
	109	203	216	232	248	264	302	307	333	375	387	410	434	459
105	201	213	229	245	262	300	304	330	372	384	406	430	456	

Heating Mode		Heating Charge Chart 3.5 TON (FOR HD2-42)												
		Indoor Dry Bulb Temperature(°F)												
		60	62	64	66	68	70	72	74	76	78	80	82	
Pressure after Switchover Valve-Suction to Compressor(psig)	135	332	340	348	356	364	372	380	388	396	404	412	420	
	128	322	330	338	346	354	362	370	378	386	394	402	410	
	121	312	320	328	336	344	352	360	368	376	384	392	400	
	114	302	310	318	324	332	340	348	356	364	372	380	388	
	107	298	304	310	316	322	328	336	344	352	360	368	376	
	100	286	292	298	304	310	316	322	330	338	346	354	362	
	93	275	281	287	293	299	305	313	321	329	337	345	356	
	86	264	270	276	282	288	294	302	310	318	326	334	344	
	79	253	259	265	271	277	283	291	299	307	315	323	331	
	72	245	251	257	263	269	275	282	289	297	305	313	321	
	65							270	277	283	292	299	305	313
	58							273	279	288	294	299	305	310
	51								276	283	290	294	299	304
	44									282	286	290	294	
	37										282	286	290	

Cooling Mode		Cooling Charge Chart 3.5 TON(FOR HD2-42+TXV)												
		Outdoor Ambient Temperature(°F)												
		55	60	65	70	75	80	85	90	95	100	105	110	115
Vapor Pressure at Large Service Valve(psig)	165			255	273	288	308	328	351	377	423	479	505	532
	161			253	270	286	306	326	349	375	421	477	503	530
	157			251	268	284	304	323	347					

9.0 INSTRUCTING THE OWNER

Assist owner with processing Warranty cards and/or online registration. Review Owners Guide and provide a copy to the owner and guidance on proper operation and maintenance. Instruct the owner or the operator how to start, stop and adjust temperature setting. The installer should instruct the owner on proper operation and maintenance of all other system components.

9.1 MAINTENANCE

1. Dirt should not be allowed to accumulate on the outdoor coils or other parts in the air circuit. Clean as often as necessary to keep the unit clean. Use a brush, vacuum cleaner attachment, or other suitable means.
2. The outdoor fan motor is permanently lubricated and does not require periodic oiling.
3. If the coil needs to be cleaned, it should be washed with Calgon Coilclean (mix one part Coilclean to seven parts water). Allow solution to remain on coil for 30 minutes before rinsing with clean water. Solution should not be permitted to come in contact with painted surfaces.
4. Refer to the furnace or air handler instructions for filter and blower motor maintenance.
5. The indoor coil and drain pan should be inspected and cleaned regularly to assure proper drainage.



CAUTION

It is unlawful to knowingly vent, release or discharge refrigerant into the open air during repair, service, maintenance or the final disposal of this unit. When the system is functioning properly and the owner has been fully instructed, secure the owner's approval.

10.0 WIRING DIAGRAM



CAUTION

These units must be wired and installed in accordance with all National and Local Safety Codes.

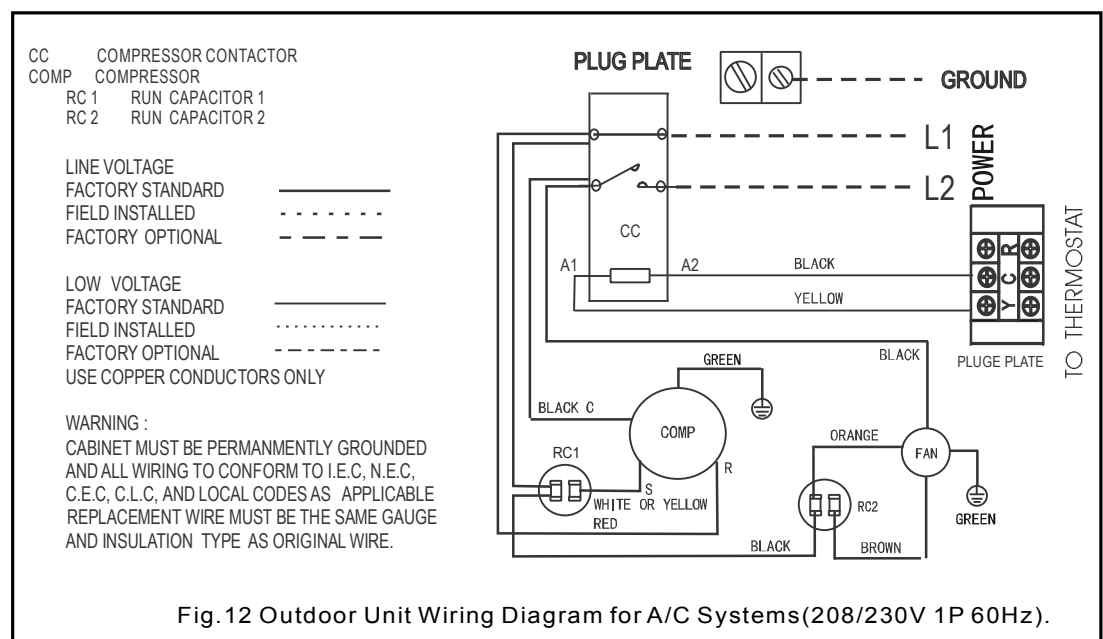

- CC COMPRESSOR CONTACTOR
- CCH CRANKCASE HEATER
- COMP COMPRESSOR
- DFC DEFROST CONTROL
- T4 AMBIENT TEMPERATURE
- T3 PIPE TEMPERATURE
- HPC HIGH PRESSURE CUT-OUT CONTROL
- LPC LOW PRESSURE CUT-OUT CONTROL
- OFM OUTDOOR FAN MOTOR
- RC 1 RUN CAPACITOR 1
- RC 2 RUN CAPACITOR 2
- RV REVERSING VALVE
- GND GROUND CHASSIS
- HGS HOT GAS SENSOR
- JUMP DEFROST JUMP 1 NORMAL / 0 FORCE

- LINE VOLTAGE
- FACTORY STANDARD _____
 - FIELD INSTALLED - - - - -
 - FACTORY OPTIONAL - - - - -

- LOW VOLTAGE
- FACTORY STANDARD _____
 - FIELD INSTALLED - - - - -
 - FACTORY OPTIONAL - - - - -
- USE COPPER CONDUCTORS ONLY

WARNING:
 CABINET MUST BE PERMANENTLY
 GROUNDED AND ALL WIRING TO CONFORM TO
 I.E.C, N.E.C, C.E.C, C.L.C, AND LOCAL CODES AS
 APPLICABLE REPLACEMENT WIRE MUST BE THE SAME
 GAUGE AND INSULATION TYPE AS ORIGINAL WIRE.

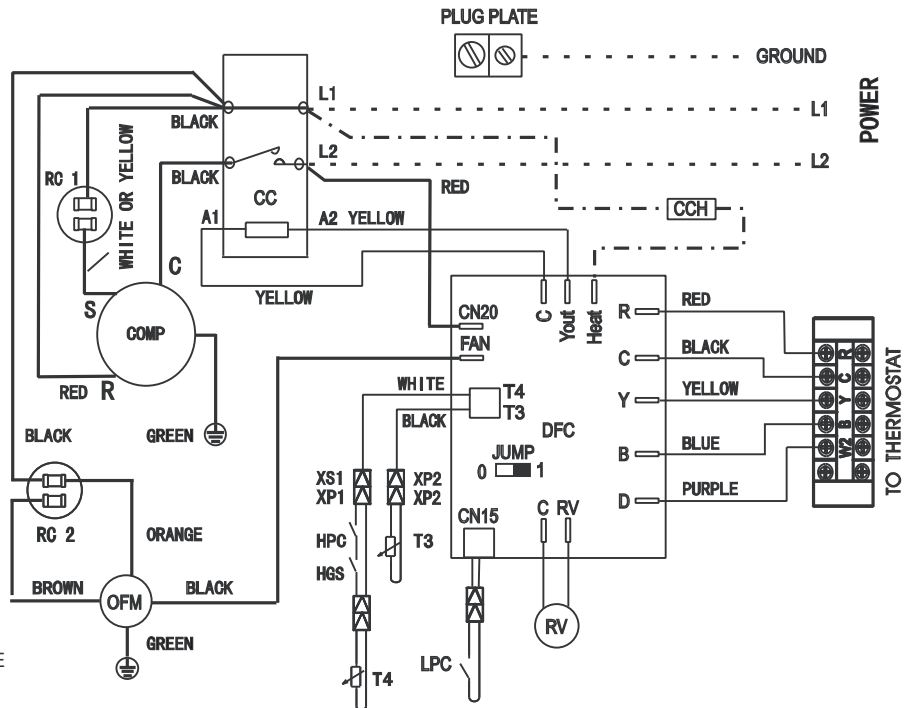

Fig.13 Outdoor Unit Wiring Diagram for H/P Systems(208/230V 1P 60Hz).

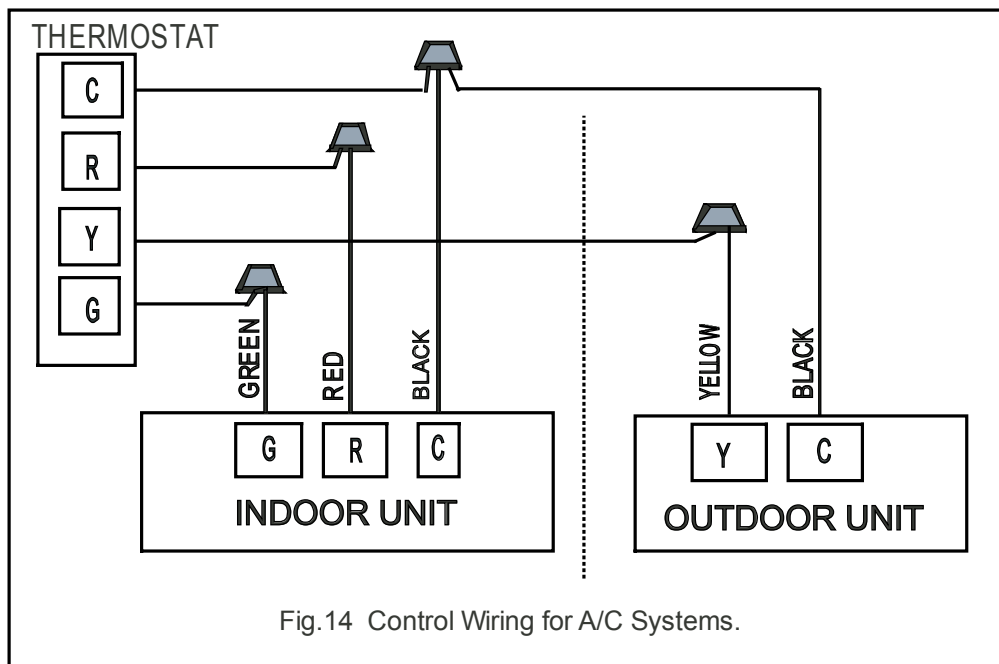

Fig.14 Control Wiring for A/C Systems.

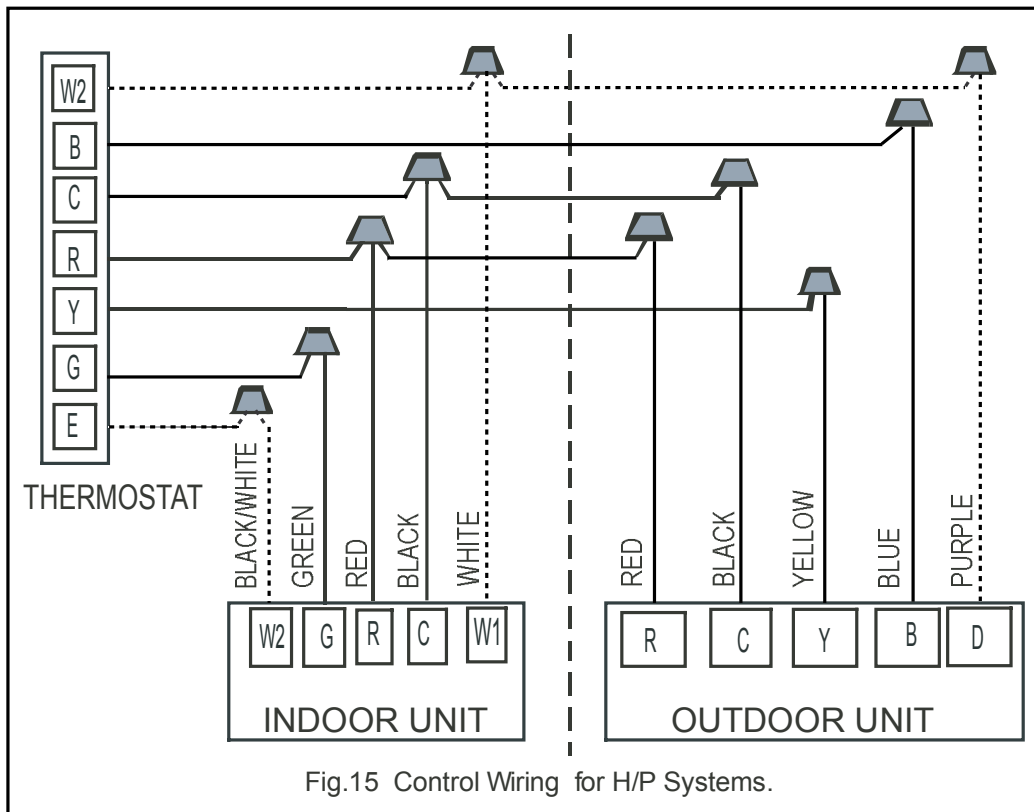

TABLE 7: Electrical Data:

Model	Min. Circuit Ampacity(A)	Maximum Circuit Protector(A)
ADA2-18-410	9.7	15
ADA2-24-410	11.9	20
ADA2-30-410	14.9	30
MAH-36-410	18	30
MAH-42-410	22.1	40
MAH-48-410	24.7	40
ADA2-60-410	29.1	50
ADH2-18-410	9.7	15
ADH2-24-410	12.0	20
ADH2-30-410	14.9	30
MHH-36-410	18	30
MHH-42-410	23.6	40
MHH-48-410	24.7	40
ADH2-60-410	29.1	50

MDV09IU-025AW

202000171426