

ComfortStar®

Submittal Data: CMO24B 24,000 Btu/h Flex Multi-Zone Wall Mounted Ductless Heat Pump System

Job Name: _____ **Location:** _____ **Date:** _____
Purchaser: _____ **Engineer:** _____
Submitted To: _____ **For:** **Review** **Approval**
Unit Tag(s): _____ **Quantity:** _____

GENERAL FEATURES

- Limited Warranty: 5 years on compressor and 1 year on parts
- Horizontal (front) discharge outdoor unit
- Flexi-multi design: allows installer to mix and match evaporators and condensers for different sized spaces
- Gold Fin protection on outdoor unit coil
- Compressor short cycle protection
- Wireless remote controller
- Error code display for easy troubleshooting
- 3 speed fan
- Auto swing louver
- Activated carbon filter
- Quiet operation
- Auto restart

OUTDOOR UNIT

Compressor type.....D.C. Inverter
R.L.A.....11.55
L.R.A.....34
Dimensions, (In).....37.4 x 33 x 16.5
Weight, (Lbs).....149
Sound levels, (dB(A)).....59
Operating temperature ranges*:
Cooling: 64 deg F - 109 deg F
Heating: 19 deg F - 75 deg F

* Low ambient operation to 0 deg F is achieved by installing an ICM326H low ambient control (not included).

GENERAL SPECIFICATIONS

Capacity, (Btu/h, Clg).....24,000
System efficiency, (SEER).....16
Capacity, (Btu/h, Htg 47deg/17deg).....29,500/17,000
System efficiency, (HSPF).....8.2
Power supply.....208-230VAC/60Hz/1 Phase
Refrigerant.....R-410A
Refrigerant pipe size (liquid x gas).....1/4"x1/2"
Connection Type.....Flare
Maximum piping length, (Ft).....60
Maximum piping height difference, (Ft).....16
Breaker size, (Amps).....25
Interconnect voltage.....208-230VAC/60Hz/1 Phase
Metering device.....Capillary Tube

Note: System is pre-charged for 16' line set.

ComfortStar®

Left side

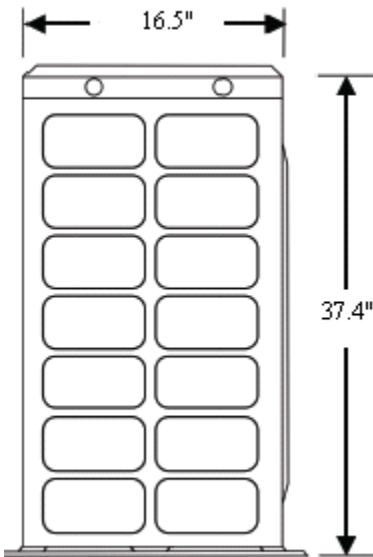

Top view

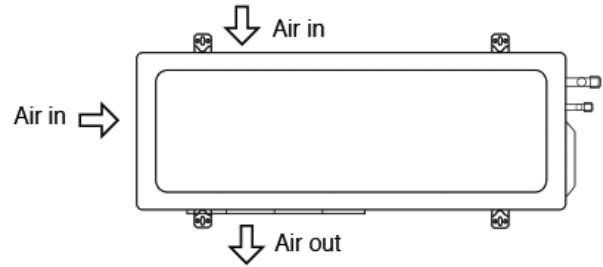

Front

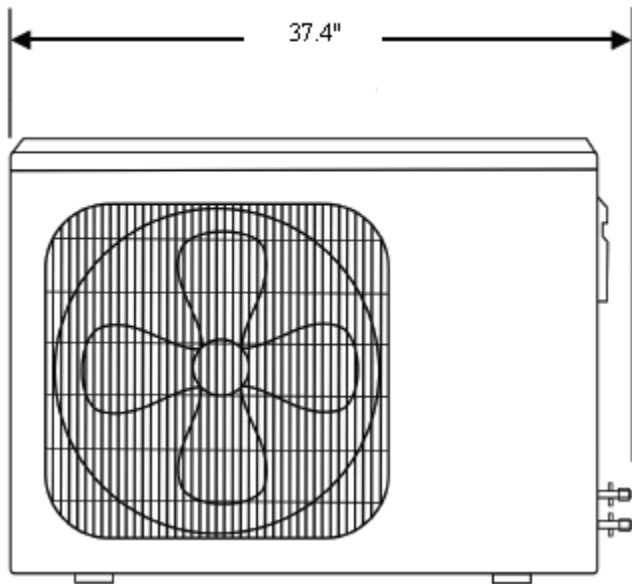

Right side

