

Condensate Pump Connection Diagram for Plus Series

(1) CCH09CA-13; CCH012CA-13; CCH012CD-13;

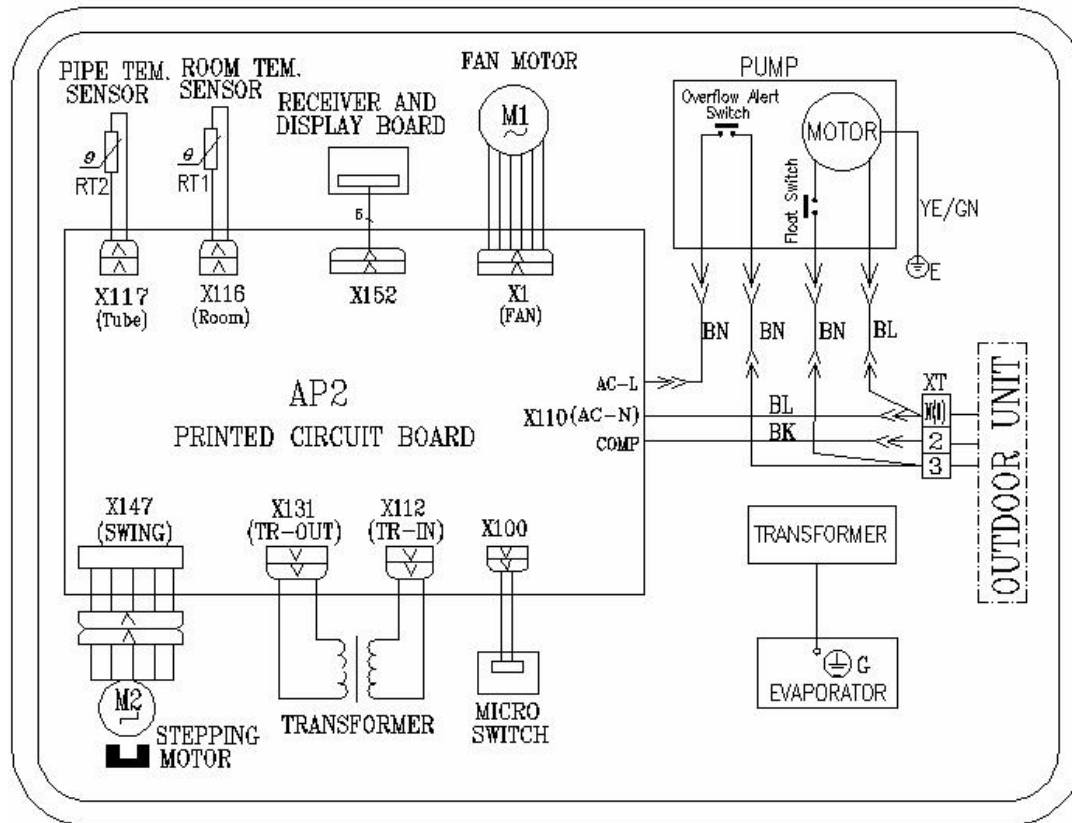

(2) CCH018CD-13

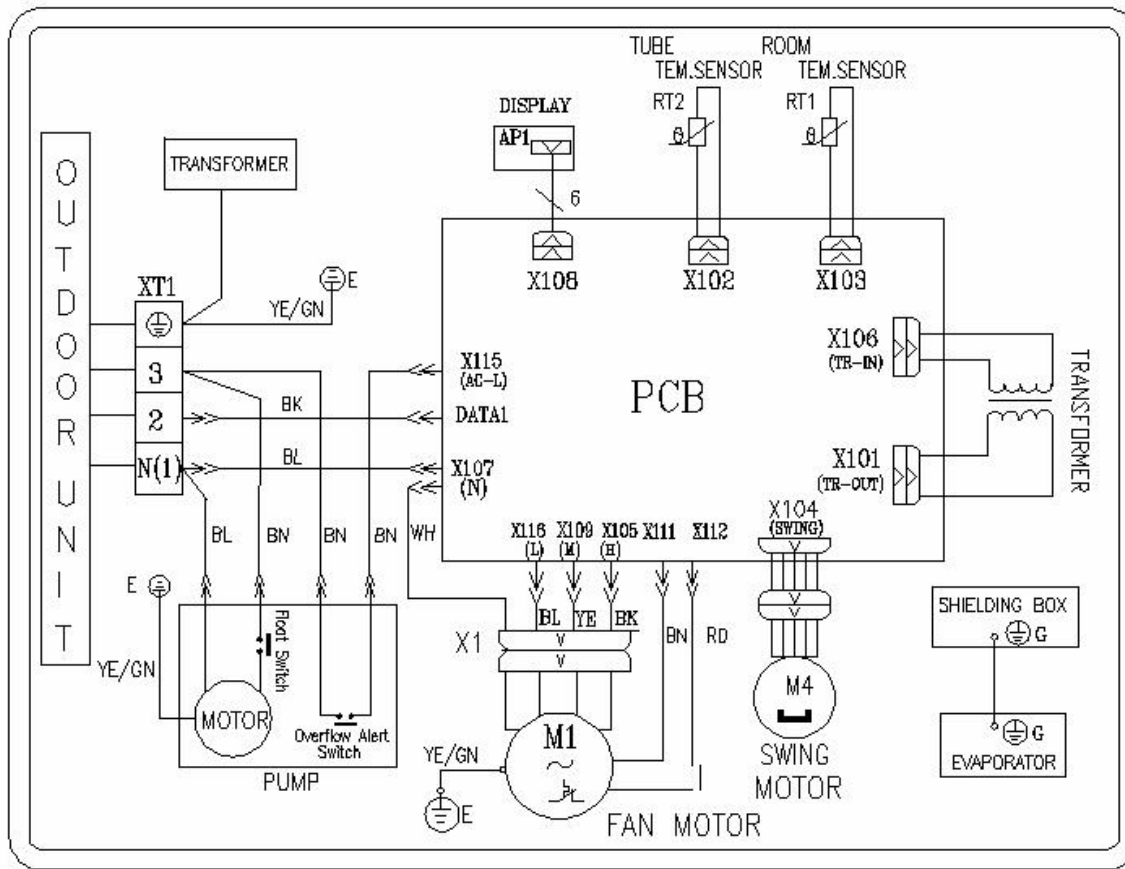

(3) CHH09CA-13; CHH012CA-13; CHH012CD-13.

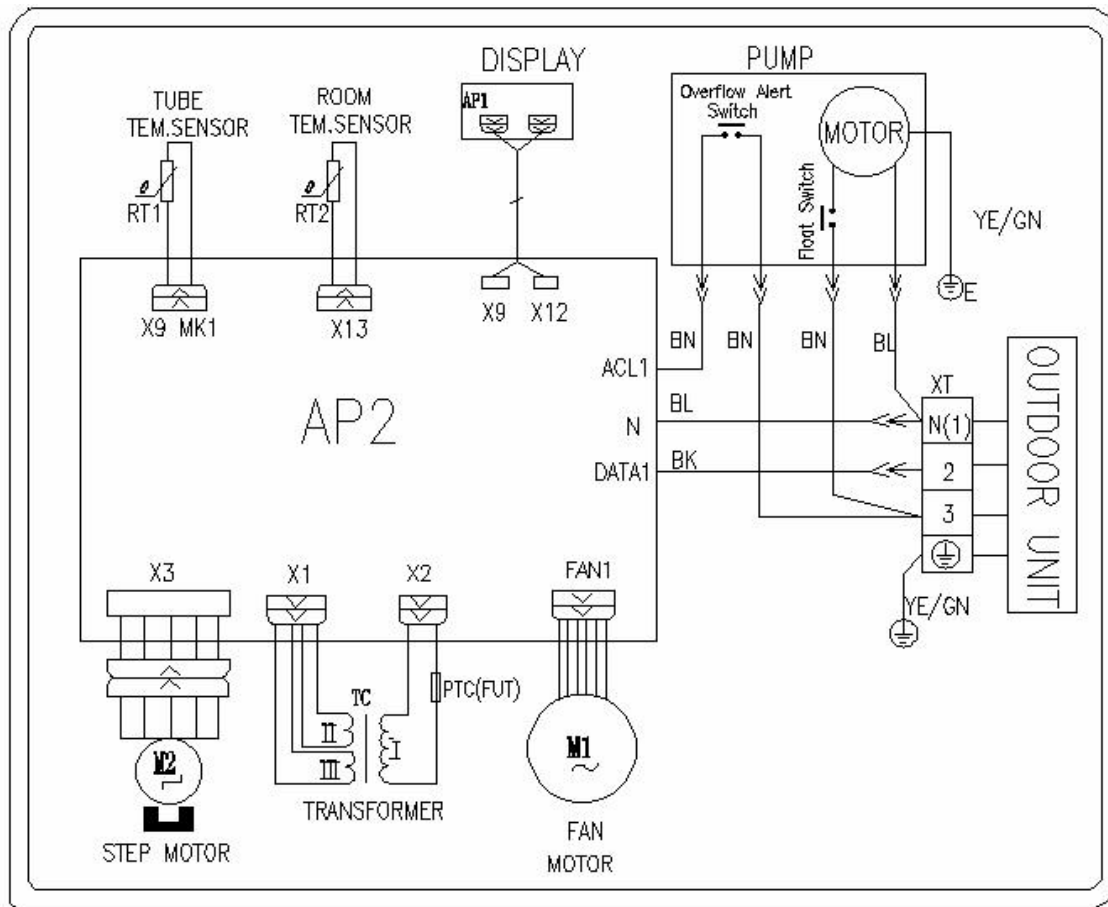

(4) CHH018CD-13

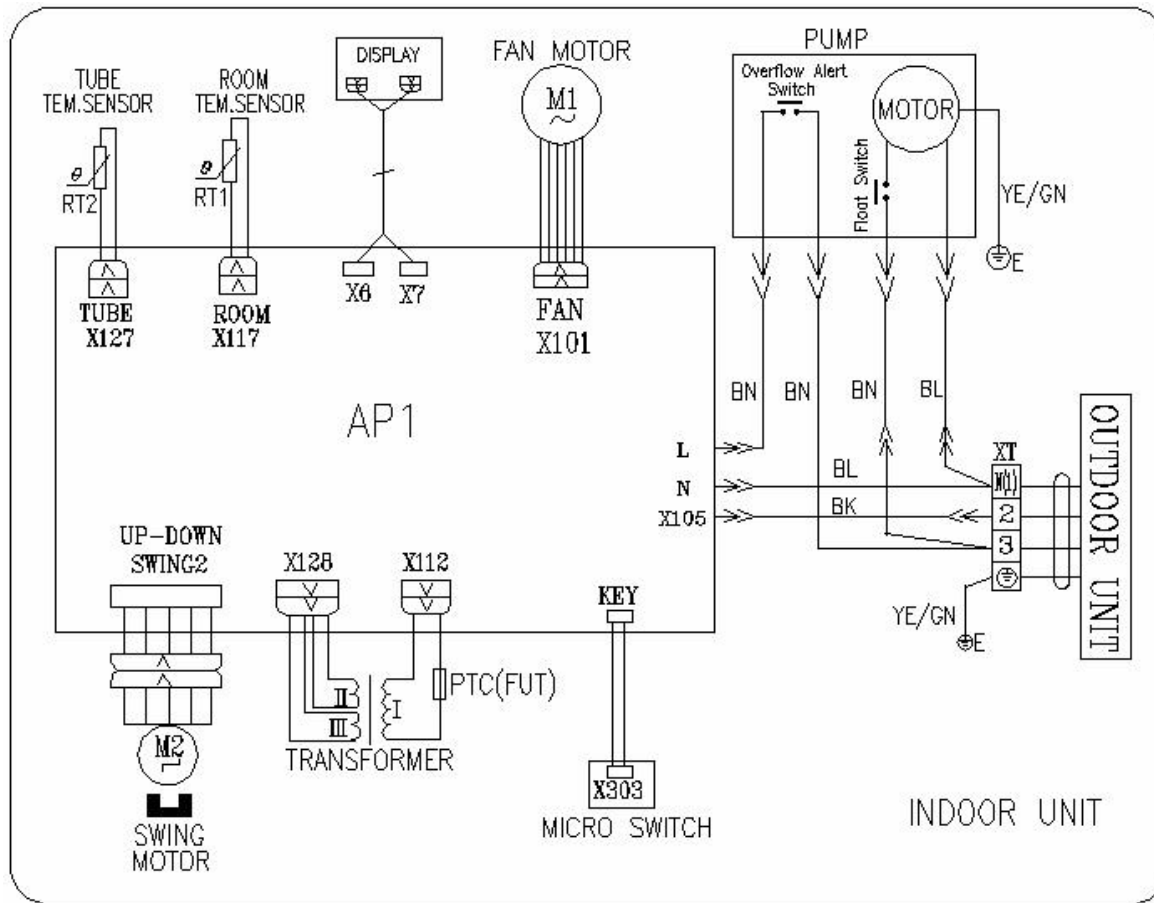

(5) CHH024CD-13

